



Ensuring the reliability of filtration systems for transport and processing machines by redundancy

Yuri Novitskiy*

Postgraduate Student

National University of Life and Environmental Sciences of Ukraine

03041, 15 Heroiv Oborony Str., Kyiv, Ukraine

<https://orcid.org/0000-0003-1115-1747>

Abstract. The relevance of this study is subordinated to the existing global trend of applying the scientific paradigm of redundancy of individual systems of transport and technological machines. This approach ensures the uninterrupted technological process of crop production following the regulatory reliability indicators. The purpose of this study was to identify failures of subsystems and elements of transport and technological machines depending on the operating time and to ensure reliability by redundancy. The study covered the methodological approaches to the formation of reliability of transport and technological machines. The study analysed the areas of ensuring the reliability of transport and technological machines on the example of machinery and equipment for animal husbandry. Methodical approaches to ensuring the indicators of reliability and maintainability during the operation of a self-propelled mixer were covered. A systematic approach to the self-propelled mixer as a complex transport and technological machine was developed. The principal subsystems that define a self-propelled mixer as a complex transport and technological system were identified. During the study, two groups of failures were identified, which lead to the loss of performance of the research objects. The features of using information and structural redundancy to improve the reliability of filtration systems of self-propelled mixers were presented. The technical condition of the engine air filter should be checked and cleaned after 50 hours, while the cartridge should be replaced after 1000 hours of operation. The functioning of the cabin filtration subsystem is ensured by a condenser, evaporator, desiccant filter, air filter, which should be checked and cleaned every 500 hours, while spare parts should be available in stock for replacement after one year of use. The formed criteria for assessing the technical condition of air filtration systems of a self-propelled mixer will provide a higher level of reliability and expand the list of their parameters.

Suggested Citation:

Novitskiy, Yu. (2024). Ensuring the reliability of filtration systems for transport and processing machines by redundancy. *Scientific Reports of the National University of Life and Environmental Sciences of Ukraine*, 20(4), 85-95. doi: 10.31548/dopovidi/3.2024.85.

*Corresponding author



The methodology presented in this study allows increasing the reliability and maintainability of self-propelled mixers, to provide a methodical approach to the formation of reliability of engine air filtration and operator's cabin air filtration subsystems

Keywords: criterion; self-propelled mixer; backup elements; engine air filter; cabin air filter

Introduction

As the use of transport and processing machines increases, so does their intensity of operation, which increases the risk of failures and malfunctions. This can lead to considerable financial losses, reduced productivity and quality of work performed. Modern machines, albeit with high reliability, require additional measures to ensure their trouble-free operation, especially after the warranty period has expired. Redundancy of filtration systems helps to increase the reliability and extend the service life of equipment, which is critical for the stable functioning of the agricultural sector. Improving maintenance systems, as well as developing innovative methodologies and mathematical models for predicting and preventing failures, are necessary steps to ensure the reliability and efficiency of transport and processing machines in modern environment. The current strategy for the development of Ukraine's agro-industrial complex envisages the purchase of a significant amount of foreign equipment, including transport and technological machinery. The issues of evaluating and ensuring the reliability of these machines point to the importance of conducting research to identify the parts and components that limit their performance.

A.V. Novitskyi *et al.* (2021; 2023) noted that a set of measures to ensure a suitable level of reliability of new transport and technological machines, supported by branded service, in difficult operating conditions is insufficient, and failures of elements, components, assemblies, and systems continue to occur. The practice of using the presented research objects indicates that the statistics of failures during their operation

is only accumulating, and service maintenance, in most cases, is focused on performing technological maintenance operations rather than repairing individual mechanisms, restoring parts, and working bodies.

As I. Revenko *et al.* (2023) notes, self-propelled and mobile mixers are among the means for preparing and distributing feed in livestock production. Therewith, they are multi-operational transport and technological systems "Human-Machine-Environment", the reliability of which depends on the components "machine", "human operator", and "environment".

Notably, the analysis of literature sources and the practice of using mobile and self-propelled mixers shows that the "machine" component is still understudied, especially from the standpoint of ensuring operability. S. Morrone *et al.* (2022) note that one of the conditions for the highly productive development of the livestock industry can be the effective use of technical service of machinery and equipment for the preparation and distribution of feed on demand. Therewith, considering the short duration and stress of their use, there is a need to monitor the indicators of maintainability.

The component "machine" has been studied in some foreign and Ukrainian scientific studies, but only from the standpoint of functioning and ensuring design and technological characteristics (Sheichenko *et al.*, 2024). Specifically, S. Postelga (2021) described methodological approaches and presented comprehensive results of a study of the efficiency of using the Siloking SelfLine 4.0 Premium 2215 self-propelled mixer-dispenser. According to the results of testing

of the main parameters and tests of Siloking SelfLine 4.0 Premium 2215, the uniformity of mixing (94.3%) and uniformity of feed distribution (95.5%) were confirmed, considering the possible types of feed. However, there are limited materials in scientific sources that present studies of the reliability properties of mixers.

M. Pristavka *et al.* (2022) discussed the advantages and features of using graphical dependencies, compared to other conventional diagrams, to assess the quality of oil purification filter elements. The researchers concluded that an adequate and accurate implementation of real-time graphs can be useful in significantly reducing costs and time while ensuring the quality of filter elements. T. Pati *et al.* (2021) states that the quality of any engineering product can be described and evaluated based on research into the following components: product specifications; reliability; performance; and compliance with standards.

J. Katsitadze *et al.* (2021) reflected the results of assessing the operational reliability of walk-behind tractors, which represent a significant group of transport and technological machines used in agricultural production. The methodology for calculating the reliability of motorblocks and the formation of the key areas for ensuring their reliability is worthy of attention. When operating certain types of equipment, including transport and processing machines, a single machine is used that can perform a series of technological operations as a single process. According to I.M. Kuzmich *et al.* (2021), multi-operating machines are characterised by an increase in overall size, performance, and complexity, which makes the loss of their operability during technological operations particularly critical. Therefore, the reliability analysis of transport and technological machines becomes necessary to establish the causes of system failure, identify subsystems, and elements to ensure their reliability.

M. I. Chornovil (2010) described redundancy methods that can be used in design, production,

and operation, and this method is one of the most effective methods of improving the reliability of technical systems, although it is costly. To ensure the reliability of machinery and equipment as technical systems, V. Kozlovskiy & B. Zalevskiy (2023) use the following types of redundancy: structural; functional; time; information; parametric; load.

The purpose of this study was to identify failures of subsystems and elements of transport and technological machines depending on the operating time and to ensure reliability by redundancy

Materials and Methods

The study was conducted in 2023–2024 at modal agricultural enterprises in Kyiv and Cherkasy oblasts, where SPW INTENSE 2 CS self-propelled mixers were operated. The SPW INTENSE 2 CS self-propelled mixer is a KUHN (France) feed preparation and distribution machine for different groups of cattle, a transport and technological machine that was operated in livestock enterprises according to the operator's manual (Operator's manual..., 2020). During operation, SPW INTENSE 2 CS was influenced by a series of objective and subjective factors that necessitated the adjustment of the manufacturer's recommendations for assessing the technical condition, replacing the working bodies and filtration elements.

The components of the object of study that formed the reliable operation of SPW INTENSE 2 CS transport and processing machines included the engine air filtration and operator cabin filtration subsystems. The engine air was filtered by an air filter. The operator's cabin was filtered by a condenser, evaporator, filter dryer, and air filter.

The SPW INTENSE 2 CS self-propelled mixer is equipped with a milling loader for self-loading. The milling mechanism ensures the integrity of the feed monolith and reduces the percentage of spoilage due to secondary fermentation. The diagram of the SPW INTENSE 2 CS self-propelled mixer is presented in Figure 1.

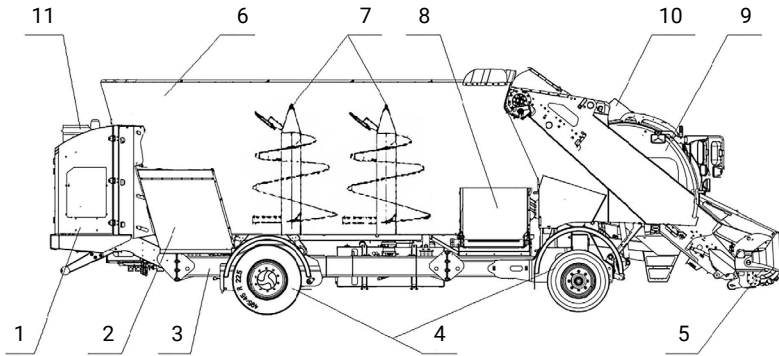

Figure 1. Self-propelled mixer SPW INTENSE 2 CS

Note: 1 – engine, 2 – discharge chute, 3 – frame, 4 – running subsystem, 5 – loading milling mechanism, 6 – hopper, 7 – mixing augers, 8 – discharge conveyor, 9 – operator's cabin, 10 – cabin air filtration subsystem, 11 – engine air filtration subsystem

Source: developed by the author of this study based on the Operator's manual (2020)

The test mode of the self-propelled mixer was set to operational. A plan was adopted to test the SPW INTENSE 2 CS self-propelled feed mixer for reliability [NMT]. The plan envisaged a certain number of test objects N , which, in case of failure, were restored M , and the research was terminated when the corresponding operating time T was reached (Chornovil, 2010).

The use of the presented self-propelled mixer (Fig. 1) in a livestock farm and interaction with feed components of different quality, degree of contamination and dusting, negatively affect the operational reliability of transport and technological machines and lead to failures. All failures recorded during operation were divided into two characteristic groups, depending on the mechanisms that lost their efficiency. The first group of failures was formed by the working bodies and parts of the mechanisms for loading feed ingredients, grinding and mixing, and unloading the feed mixture. The service life of these mechanisms depends on the influence of objective and subjective factors, while the frequency of replacement depends on the permissible and limit parameters, criteria for the limit state of the working bodies.

The second group of failures was made up of mechanisms whose maintenance intervals are

determined by the planned preventive maintenance and repair system, which is formed by the manufacturer in the operator's manual (Operator's manual..., 2020). Such parts and elements include components of the filtration systems of SPW INTENSE 2 CS mixers.

The parameters and reliability characteristics of transport and technological machines were ensured based on an integrated approach, the essence of which is to ensure the operability of self-propelled mixers, considering the interconnection of reliability, maintainability, and operational and technical characteristics using the redundancy methodology. Below, the study presents the possibility of using information and structural redundancy of self-propelled mixers. Information redundancy in ensuring the reliability of research objects involves the use of additional information beyond that required for the efficient use and performance of production tasks. Structural redundancy involves the use of an excessive number of elements that are not part of the structure of the research object. The implementation of a structural redundancy method to increase the reliability of the filtration subsystems of a self-propelled mixer is ensured by the use of backup elements to the main one.

Results and Discussion

The process of feed distribution by self-propelled mixers and feed dispensers is less sensitive to technical malfunctions, however, the practice of use shows that during operation, failures of the mechanisms for loading feed, grinding and mixing, and unloading feed mixtures occur. Despite a series of these disadvantages, only self-propelled mixers and feed dispensers can be used to mechanically distribute feed mixtures at exercise grounds and summer camps. The practice of us-

ing self-propelled mixers has established that, as a result of the intensity of operating conditions and considerable contamination of feed storage and transportation areas, animal housing, there is a need to adjust the information on the frequency of replacement and substantiate the required number of backup elements of air filtration subsystems to ensure single and complex reliability indicators. The maintenance intervals for the filtering subsystems of the SPW INTENSE 2 CS mixer units, presented in Table 1, are considered.

Table 1. Maintenance intervals for the filtering subsystems of the SPW INTENSE 2 CS mixer units with morphological symbols

| Morphological symbol / list of maintenance works | Frequency of maintenance | | | | | |
|---|--------------------------|-----------|-----------|------------|------------|---------|
| | 50 hours | 100 hours | 500 hours | 1000 hours | 2000 hours | 2 years |
| a. Cleaning | | | | | | |
| J a1. Air filter for a diesel engine. | + | - | - | - | - | - |
| J a2. Air filter for the cabin | + | - | - | - | - | - |
| J a3. Evaporator and condenser of an air conditioning system. | - | - | + | - | - | - |
| b. Replace | | | | | | |
| J b1. Diesel engine air filter cartridges. | - | - | - | + | - | - |
| J b2. Dehumidifying filter for the air conditioning system. | - | - | - | - | + | + |
| J b3. Air filter for the cabin | - | - | - | - | + | + |

Source: developed by the author of this study

The study analysed the filtration subsystems of SPW INTENSE 2 CS, which influence the formation of reliability of the machine and operator components and include: cabin filtration; engine filtration. The study considered the components of the subsystem for filtering the cabin and maintaining comfortable working conditions for the human operator. The main components that ensure the reliable operation of this subsystem are as follows: condenser; evaporator; filter dryer; air filter. The engine filtering subsystem of the self-propelled mixer includes such filters as air; fuel; oil purification; engine oil evaporation.

The functionality of the morphological symbols (Table 1) allows presenting a collapsed matrix model of the morphological description

of the maintenance intervals of the filtering subsystems of the SPW INTENSE 2 CS mixer unit:

$$M_I = \begin{bmatrix} a.1 \\ a.2 \\ a.3 \end{bmatrix} + \begin{bmatrix} b.1 \\ b.2 \\ b.3 \end{bmatrix}, \quad (1)$$

where M_I is the level I functionality of the main objectives of the synthesis of the maintenance frequency system for the filtering subsystems of the mixer units. Considering the functionality according to expression (1), its general form can be obtained as follows:

$$M_I = |M_a| \cap |M_b|, \quad (2)$$

where M_a is the level II functionality of the main objectives of the synthesis of technological

operations to clean in the maintenance frequency system for the filtering subsystems of the mixer units; M_b is the level II functionality of the main objectives of the synthesis of technological operations to replace in the maintenance frequency system of the filtering subsystems of the mixer units.

Considering the standards (Table 1) for conducting technological operations of replacement in the system of periodicity of maintenance of the filtering subsystems of the mixer units, according to expression (2), we can obtain the norm of combinations of divided hierarchical groups in the amount of 49. Thus, it is 49 partial technical solutions that can be analysed at alternative levels. This alternative will meet the regulatory reliability of a complex technical system.

In performing the functions of the SPW INTENSE 2 CS transport and processing machine, events occur in its elements, some of which lead to a decrease in the reliability of the objects under study. Another group of events includes those failures that lead to a negative impact on

the functioning of the human-operator component. Of particular interest is not only the assessment of the reliability of the object of study and the frequency of maintenance, but also the assessment of maintainability, i.e., the time that the operator of a transport and technological machine must spend to restore its performance. Not all manuals for self-propelled mixers contain information on maintainability, including the average time to repair. This is especially true for the subsystems and mechanisms that ensure the functioning of the main systems of the feed preparation and distribution equipment. Such subsystems and mechanisms include the components of filtering subsystems. Let us analyse the criteria for assessing the technical condition of the filter subsystems of a self-propelled mixer. The individual filter subsystems are equipped with sensors that indicate when the filter is dirty. The results of the analysis of the technical condition assessment criteria for engine air filters and cabin filters are presented in Table 2.

Table 2. Analysis of the criteria for assessing the technical condition of the filter systems of the SPW INTENSE 2 CS self-propelled mixer



| Name of the filter elements | Display of filter elements in the user manual | Criteria for assessing the technical condition |
|-----------------------------|---|--|
| Cabin air filter | | |
| Capacitor |  | If dirty, the air conditioning system may shut down. Periodic inspection of the technical condition |
| Evaporator |  | Periodic check of the evaporator's technical condition |
| Dehumidifier filter |  | Periodic check of the evaporator's technical condition |

Table 2. Continued

| | | |
|----------------------------------|---|--|
| Air filter |  | Periodic check of the evaporator's technical condition |
| Engine air filter | | |
| Diesel engine air filter element |  | Engine air filter element pressure sensor |

Source: developed by the author of this study

Based on the presented analysis of the SPW INTENSE 2 CS mixer as a component of the transport and technological system “Human-Machine-Environment”, it can be argued that ensuring the operability of the filtering subsystems of the self-propelled mixer can be achieved through scientific and methodological redundancy approaches. To better investigate the state of the issue, let us formulate appropriate recommendations that reflect the filtering elements, indicate the sequence of research of these events, the possibility of occurrence and prevention of failures through redundancy. The technical condition of the engine air filter should be checked and cleaned after 50 hours, while the cartridge should be replaced after 1000 hours of operation. Control of the functioning of the cab filtration subsystem and cleaning of components should be carried out after 500 hours, while the spare parts should be planned in the reserve and replaced after 1 year of use, or 2000 hours. The analysis of the presented results suggests that most authors in recent years have conducted research on transport and technological machines towards improving design and technological parameters and increasing the efficiency of their use.

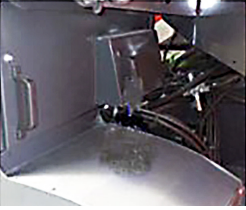
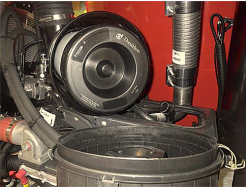
Comparing the findings obtained in this study and the approach to ensuring the reliability of

transport and technological machines with other studies, the following can be noted: the issue of improving the reliability of the research objects presented herein was not considered with regard to the study of filtering systems for engines, units, and subsystems that ensure the functioning of machine-tractor units (Abed *et al.*, 2022), combine harvesters (Najafi *et al.*, 2015), and feed preparation equipment (Revenko *et al.*, 2023).

Some scientists have conducted research into the design and improvement of filtration elements in the car cabin. X. Dong *et al.* (2021) presented practical approaches to fan selection, filter and housing design, parts manufacturing, filtration unit assembly, and recommendations for the operation process. Thanks to the use of an engineered filter air purifier, the cabin air purifier can remove harmful substances such as formaldehyde. This is only part of a long-term programme to use air purifiers that can also be used for other transport and processing machines. However, this study does not contain recommendations for improving the functioning of the condenser and evaporator.

M. Gailis & V. Pirs (2011) evaluated the existing frequency of replacement of the Renault engine air filter and determined the impact of this operation on some vehicle performance indicators. The experience of use, operating costs,

and the factual condition of the vehicle are linked to a scientifically substantiated maintenance and repair system. The authors of the study note that the engine air filter replacement intervals declared by Renault range within 30–120 thsd km, depending on the model and type of engine. However, based on the results of testing the car on dusty roads, it is recommended to reduce the replacement interval by half. The authors of the presented study also point out the need to reduce the frequency of monitoring and cleaning the engine air filter when using a self-propelled mixer in dusty conditions, and to replace it based on the results of diagnostics or according to the criteria of the limit state.

T. Dziubak & G. Boruta (2021) highlighted the theoretical and experimental studies of the air filter of the engine of caterpillar vehicles. The paper presents a study of the influence of mineral dust in the air sucked through the filtration system on the accelerated wear of engine parts. According to the researchers, the study of regression models of engine air filters functioning for individual vehicles is of significant scientific and practical significance, as it allows to move from a planned preventive strategy for the use of air filters operated on special vehicles in conditions of variable dustiness to strategies according to their factual technical condition.

Along with the presented scientific findings, there are a series of studies in the technical literature that experimentally and numerically investigate the effect of air filter design on various parameters, on the efficiency and performance of the vehicle engine. T. Dziubak & G. Boruta (2021) and D. Thomas *et al.* (2021) describe the influence of the following parameters of filter elements on the performance of engines of mobile power vehicles: pleat height; pleat spacing; pleat shape; average filter thickness; air velocity on constant fuel consumption; dust load.

S. Anchal *et al.* (2022) obtained analogous results, since the reliability of filter systems of transport and technological machines in the dominant component depends on the reserved

machine. Such studies have resulted in the formation of a multifunctional reliability capability, which forms a single continuous process. As the size and complexity of the filter systems of transport and processing machines continue to grow, the consequences of failures of these systems are expected to become more complex and critical. Since, according to F. Tian *et al.* (2020), the analysis of filter systems of transport and technological machines is necessary to identify weaknesses in these systems and monitor components with low reliability for a given operational performance.

The findings obtained allow correlating them with those previously presented in R. Majdan *et al.* (2017). Specifically, there is a similarity in the three circuits of the mobile energy filtration system in the production cycle of crop production. Thus, it is possible to develop universal filtration systems for agricultural machinery.

The task of ensuring the appropriate level of reliability arises at all stages of the life cycle of self-propelled mixers, which necessitates a comprehensive analysis, selection, substantiation of evaluation methods and ensuring the reliability and maintainability of systems.

Conclusions

Based on the findings of the study, a comprehensive methodology was developed to ensure the operational reliability of transport and technological machines. Specifically, a detailed system analysis of the SPW INTENSE 2 CS self-propelled mixer was performed, based on which practical recommendations were formulated for maintenance and increased reliability by redundancy of critical subsystems, such as engine and air filtration in the operator's cabin.

One of the key aspects of ensuring the high reliability and ergonomics of the SPW INTENSE 2 CS is regular maintenance, including inspection of the technical condition, prompt replacement of the filter elements and provision of a reserve. According to the developed recommendations, the engine air filter cartridge needs to be reserved and replaced every 1000 hours of operation. Cabin air filtration

elements must be replaced every 2000 hours of operation. This helps to avoid unforeseen malfunctions and extend the life of the equipment.

Particular attention is also paid to the maintenance of the filtration systems of the pneumatic systems of the power plant unit and the operator's seat. To maintain their reliability, regular checks should be carried out at 50-hour intervals. An essential element is also the maintenance of air conditioning systems every 2 years, which ensures comfortable working conditions for the operator and long-term uninterrupted operation of the equipment.

The developed methodology can be adapted to other transport and technological machines used in various industries, such as agriculture, transport, construction, and industry. This will help to create more efficient, reliable, and durable transport and technological complexes that will ensure a prominent level of productivity and safety in various technological operations. The implementation of this methodology will

considerably reduce maintenance and repair costs and increase the efficiency of vehicle and technology use, which will ultimately have a positive impact on the economic performance of enterprises.

A promising task for further research is to synthesise innovative implementations of Smart technologies for the reliability of filtration systems of transport and technological machines with redundancy in the Agriculture 4.0 concept.

Acknowledgements

The author of this study would like to express his gratitude to the Centre for Collective Use of Scientific Equipment for the Latest Agricultural Technologies 'Agroindustrial Complex, Forestry, Gardening and Veterinary Medicine', which operates at the National University of Life and Environmental Sciences of Ukraine.

Conflict of Interest

The author of this study declares no conflict of interest.

References

- [1] Abed, Y., Hasan., T., & Zehawi, R. (2022). Cost prediction for roads construction using machine learning models. *International Journal of Electrical and Computer Engineering Systems*, 13(10), 927-936. doi: [10.32985/ijeces.13.10.8](https://doi.org/10.32985/ijeces.13.10.8).
- [2] Anchal, S., Ailawalia, P., & Shakuntala, A. (2022). [RAM \(Reliability, Availability and Maintainability\) of threshing machine in agriculture](#). *Agriculture and Natural Resources*, 55(6), 1057-1061.
- [3] Chornovil, M.I. (Ed.).(2010). *Reliability of agricultural machinery*. Kropyvnytskyi: CODE.
- [4] Dong, X. (2021). Design of a filtering car air purifier. *IOP Conference Series: Earth and Environmental Science*, 632, article number 052095. doi: [0.1088/1755-1315/632/5/052095](https://doi.org/0.1088/1755-1315/632/5/052095).
- [5] Dziubak, T., & Boruta, G. (2021). Experimental and theoretical research on pressure drop changes in a two-stage air filter used in tracked vehicle engine. *Separations*, 8, article number 71. doi: [10.3390/separations8060071](https://doi.org/10.3390/separations8060071).
- [6] Gailis, M., & Pirs, V. (2011). [Research in influence of engine air filter replacement periodicity](#). *Engineering for Rural Development*, 10, 173-178.
- [7] Katsitadze, J., Phutkaradze, Z., Kutelia, G. & Beridze, G. (2022). [Theoretical and experimental study of the operational reliability of small-sized agricultural machinery operating in the mountainous conditions of Adjara](#). *Mechanization in Agriculture & Conserving of the Resources*, 66(2), 57-60.
- [8] Kozlovskiy, V., & Zalevskiy, B. (2023). The method of ensuring the reliability of single-channel wireless telecommunication networks under the condition of minimizing the amount of resources involved. *Science Based Technology*, 2(58), 164-170. doi: [10.18372/2310-5461.58.17653](https://doi.org/10.18372/2310-5461.58.17653).
- [9] Kuzmich, I.M., Rogovskii, I.L., Titova, L.L., & Nadtochiy, O.V. (2021). Research of passage capacity of combine harvesters depending on agrobiological state of bread mass. *IOP Conference Series: Earth and Environmental Science*, 677, article number 052002. doi: [10.1088/1755-1315/677/5/052002](https://doi.org/10.1088/1755-1315/677/5/052002).

- [10] Majdan, R., Tkáč, Z., Abrahám, R., Kollárová, K., Vitázek, I., & Halenár, M. (2017). Filtration systems design for universal oils in agricultural tractors. *Tribology in Industry*, 39(4), 547-558. doi: [10.24874/ti.2017.39.04.14](https://doi.org/10.24874/ti.2017.39.04.14).
- [11] Morrone, S., Dimauro, C., Gambella, F., & Cappai, M.G. (2022). Industry 4.0 and precision livestock farming (PLF): An up to date overview across animal productions. *Sensors*, 22(12), article number 4319. doi: [10.3390/S22124319](https://doi.org/10.3390/S22124319).
- [12] Najafi, P., Asoodar, M.A., Marzban, A., & Hormozi, M.A. (2015). Reliability analysis of agricultural machinery: A case study of sugarcane chopper harvester. *AgricEngInt: CIGR Journal*, 17(1), 158-165. doi: [10.22616/Erdev2019.18.N387](https://doi.org/10.22616/Erdev2019.18.N387).
- [13] Novitskiy, A.V., Banniy, O.O., Novitskiy, Yu.A., & Antal, M.V. (2023). A study of mixer-feeder equipment operational reliability. *Machinery & Energetics*, 14(4), 101-110. doi: [10.31548/machinery/4.2023.101](https://doi.org/10.31548/machinery/4.2023.101).
- [14] Novitskiy, A.V., Kharkovskiy, I.S., & Novitskiy, Yu.A. (2021). Monitoring the technical condition of agricultural machinery for guideline materials for its operation. *Machinery & Energetics*, 12(4), 85-93. doi: [10.31548/machenergy2021.04.085](https://doi.org/10.31548/machenergy2021.04.085).
- [15] Operator's manual. Mixer feeder wagon. SPW INTENSE 2 CS. (2020). Retrieved from https://nubip.edu.ua/sites/default/files/u132/an112bgb_a_profiie_12.2-13.2.pdf.
- [16] Pati, T., Kabra, S., & Chadha, U. (2021). Statistical quality study of the parts produced in an automobile industry: a daimler india case study. ICRAMEN 2021. *IOP Conference Series: Materials Science and Engineering*, 1206, article number 012022. doi: [10.1088/1757-899X/1206/1/012022](https://doi.org/10.1088/1757-899X/1206/1/012022).
- [17] Postelga, S. (2021). Self-propelled mixer-distributor siloking selfline 4.0 Premium 2215 testing. *Agricultural Machinery and Equipment: Forecasting, Design, Testing*, 28(42), 150-161. doi: [10.31473/2305-5987-2021-1-28\(42\)-12](https://doi.org/10.31473/2305-5987-2021-1-28(42)-12).
- [18] Pristavka, M., Kangalov, P., Findura, P., Beloov, I., Kapela, K., & Nikolov, M. (2022). [Monitoring the defect rate of selected products](#). *Agricultural, Forest and Transport Machinery and Technologies*, IX(1), 26-32.
- [19] Revenko, I., Khmelovskiy, V., Revenko, Y., Rebenko, V., & Potapova, S. (2023). Justification of parameters affecting increase of hammer crusher productivity. *Engineering for Rural Development*, 22, 714-720. doi: [10.22616/ERDev.2023.22.TF142](https://doi.org/10.22616/ERDev.2023.22.TF142).
- [20] Sheichenko, V., Petrachenko, D., Koropchenko, S., Rogovskii, I., Gorbenko, O., Volianskiy, M., & Sheichenko, D. (2024). Substantiating the rational parameters and operation modes for the hemp seed centrifugal dehuller. *Eastern-European Journal of Enterprise Technologies*, 2(1(128)), 34-48. doi: [10.15587/1729-4061.2024.300174](https://doi.org/10.15587/1729-4061.2024.300174).
- [21] Thomas, D., Pacault, S., Charvet, A., Bardin-Monnier, N., & Appert-Collin, J.C. (2019). Composite fibrous filters for nano-aerosol filtration: pressure drop and efficiency model. *Separation and Purification Technology*, 215, 557-564. doi: [10.1016/j.seppur.2019.01.043](https://doi.org/10.1016/j.seppur.2019.01.043).
- [22] Tian, F., Chen, Y., Song, Z., Yan, Y., Fade, L., Wang, Z., & Xiong, B. (2020). Finite element simulation and performance test of loading and mixing characteristics of self-propelled total mixed ration mixer. *Journal of Engineering*, 12, article number 875816. doi: [10.1155/2020/6875816](https://doi.org/10.1155/2020/6875816).

Реалізація надійності систем фільтрації транспортно-технологічних машин резервуванням

Юрій Новицький

Аспірант

Національний університет біоресурсів і природокористування України

03041, вул. Героїв Оборони, 15, м. Київ, Україна

<https://orcid.org/0000-0003-1115-1747>

Анотація. Актуальність дослідження підпорядковано існуючому світовому тренду застосування наукової парадигми резервування окремих систем транспортно-технологічних машин. Такий підхід забезпечує беззупинковий технологічний процес виробництва сільськогосподарських культур із дотримання нормативних показників надійності. Метою дослідження є виявлення відмов підсистем та елементів транспортно-технологічних машин в залежності від часу експлуатації та забезпечення надійності резервуванням. В статті розкрито методологічні підходи до формування надійності транспортно-технологічних машин. Проаналізовано напрямки забезпечення показників надійності транспортно-технологічних машин на прикладі машин та обладнання для тваринництва. Розкрито методичні підходи до забезпечення показників безвідмовності та ремонтпридатності в процесі експлуатації самохідного змішувача. Сформовано системний підхід до самохідного змішувача як складної транспортно-технологічної машини. Встановлені основні підсистеми, які визначають самохідний змішувач як складну транспортно-технологічну систему. Під час проведення досліджень визначені дві групи відмов, які призводять до втрати працездатності об'єктів досліджень. Представлено особливості використання інформаційного та структурного резервування для підвищення надійності систем фільтрації самохідних змішувачів. Контроль технічного стану повітряного фільтра двигуна та його очищення слід проводити через 50 годин, а мати в комплекті резервних елементів картридж через 1000 годин експлуатації. Функціонуванні підсистеми фільтрації кабіни забезпечують конденсатор, випарник, фільтр осушувач, повітряний фільтр, контролювати технічний стан яких та очищати слід через 500 годин, а передбачити наявність в резерві запасних частин для заміни через рік використання. Сформовані критерії оцінки технічного стану фільтрувальних систем повітря самохідного змішувача забезпечать більш вищий рівень надійності, розширить перелік їх параметрів. Наведена в статті методологія дає можливість підвищити показники безвідмовності та ремонтпридатності самохідних змішувачів, забезпечити методичний підхід до формування надійності підсистем фільтрації повітря двигуна та фільтрації повітря кабіни оператора

Ключові слова: критерій; самохідний змішувач; резервні елементи; фільтр повітряний двигуна; фільтр повітряний кабіни